

ACOUSTICAL LOUVER

DESCRIPTION

ACL Series Acoustical louvers are designed to provide optimal noise reduction with minimal airflow restrictions. Acoustically insulated blades and varying louver depths provide sound attenuation as well as protect against weather penetration with an architecturally pleasing appearance.

STANDARD CONSTRUCTION

- Frame:** 150 mm, 200 mm, 300 mm deep, channel type, 2.0 mm thick formed aluminum.
- Blades:** 2.0 mm thick formed aluminum, positioned at 45° angle.
- Acoustic Infill:** Fiberglass Insulation.
- Insulation Cover:** Perforated Aluminum.
- Screen:** Removable expanded aluminum bird screen. Located on interior.
- Construction:** Mechanically fastened.
- Finish:** Mill with touch up on welds
- Dimensions:** Minimum size: 300 mm x 450 mm
Maximum size: 1500 mm x 2400 mm
Multiple section sizes available
“A” (width) and “B” (height) are opening sizes. Louvers are made 6 mm undersized.

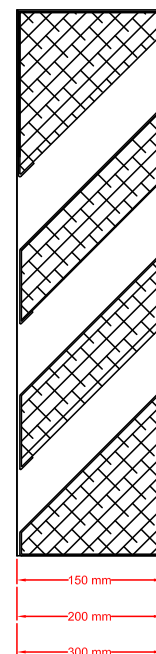
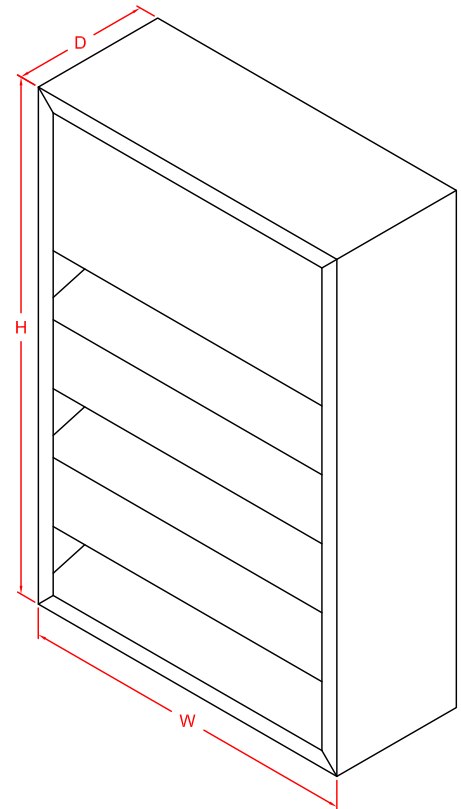

OPTIONS

- Formed Steel Construction
- Stainless Steel Construction
- Variety of Bird and Insect Screens
- Flanged Frame
- Filter Rack
- Washable Filters
- Hinged Frame
- Clip Angles
- Selection of Finishes: Super Durable Polyester Powder coatings, Kynar/PVF and anodized.

ACL Performance Data

Below ACL performance charts are based on tests performed at Cert-Aire Laboratory at Arlington Heights, Illinois based on AMCA Publication 511 for Air Performance and Water Penetration.

Aerodynamic Performance

Free Area:

Total open area of a louver after subtracting all obstructions - blades and frame

Airflow Resistance:

Pressure Differential across the louver at various free area velocities

Airflow Resistance

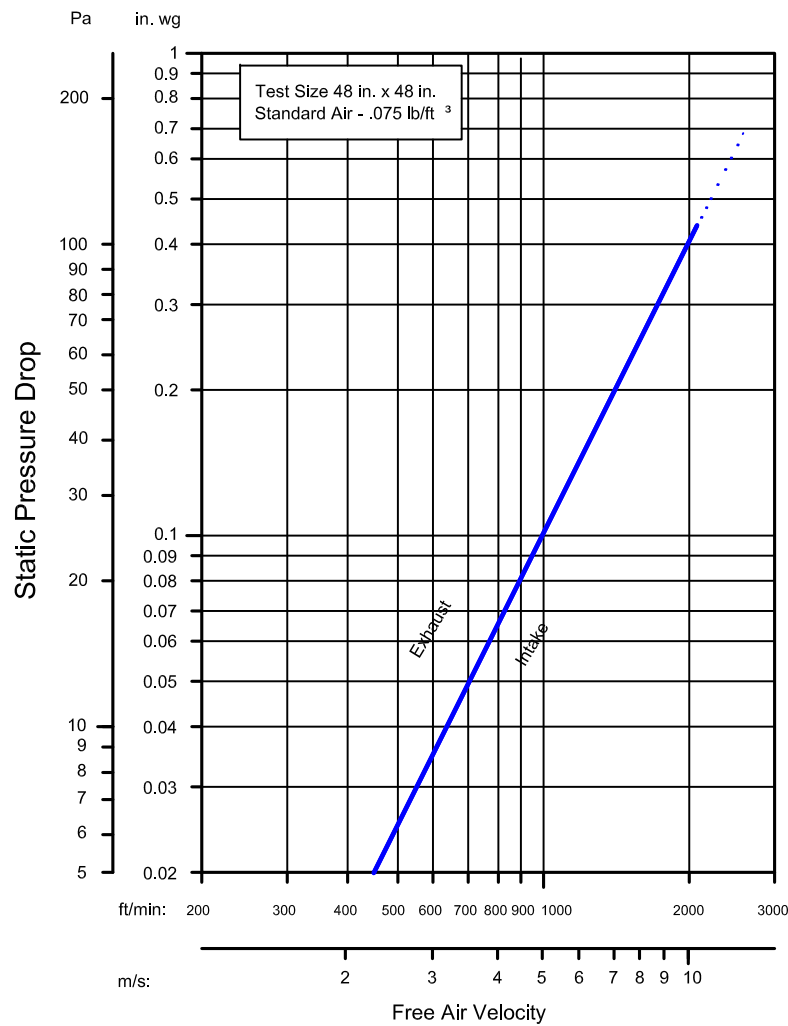

ACL Performance Data

Water Penetration:

First Point of Water Penetration is the point at which a louver first allows the passage of water through the louver. It is measured by the air intake velocity at which the louver will begin leaking.

Frame Thickness (mm)	Free Area (%)	Beginning of Water Penetration (m/s)	Pressure Drop (Pa) (at Beginning of Water Penetration Velocity)
150	34	4.06	16
200	30	4.57	18
300	26	5.00	23

Acoustic Performance

Sound Transmission Class (STC):

The Sound Transmission Class (STC) is a rating of the effectiveness of an assembly in isolating or reducing airborne sound transmission. STC is a single number that summarizes airborne sound transmission loss data. Assemblies with higher STC ratings are more efficient at reducing sound transmission. STC is determined in accordance with ASTM E413-04.

Transmission Loss:

Transmission loss (TL) is a measurement of the reduction of sound power transmission (dB) through an assembly at a given frequency. The more sound power that is reduced, the greater the TL. TL is tested in accordance with ASTM E90-04.

Noise Reduction:

Noise Reduction is the difference between the sound pressure level on the noise source side of the louver and the free field sound pressure level on the receiver side of the louver. Free Field Noise Reduction is determined by adding 6 dB to the Transmission Loss.

Thickness (mm)	Noise Reduction (dB)							
	125Hz	250Hz	500Hz	1000Hz	2000Hz	4000Hz	STC	NR
150	10	10	12	16	23	18	10	16
200	11	11	13	19	28	20	12	18
300	13	12	17	25	36	25	16	22

